



浙江大学计算机学院
数字媒体与网络技术

Digital Asset Management

数字媒体资源管理



2. Introduction to Digital Media Format

任课老师：张宏鑫

2020-09-22

大程组队预告

- 5人左右（9月24日）
- 互助学习，共同探索
- 共同完成大程
 - 每组分配一个树莓派（ ≤ 12 个，可选用）
 - 分工合作，可有侧重
- 但每次回家作业独立完成



About Raspberry PI

<https://www.raspberrypi.org>

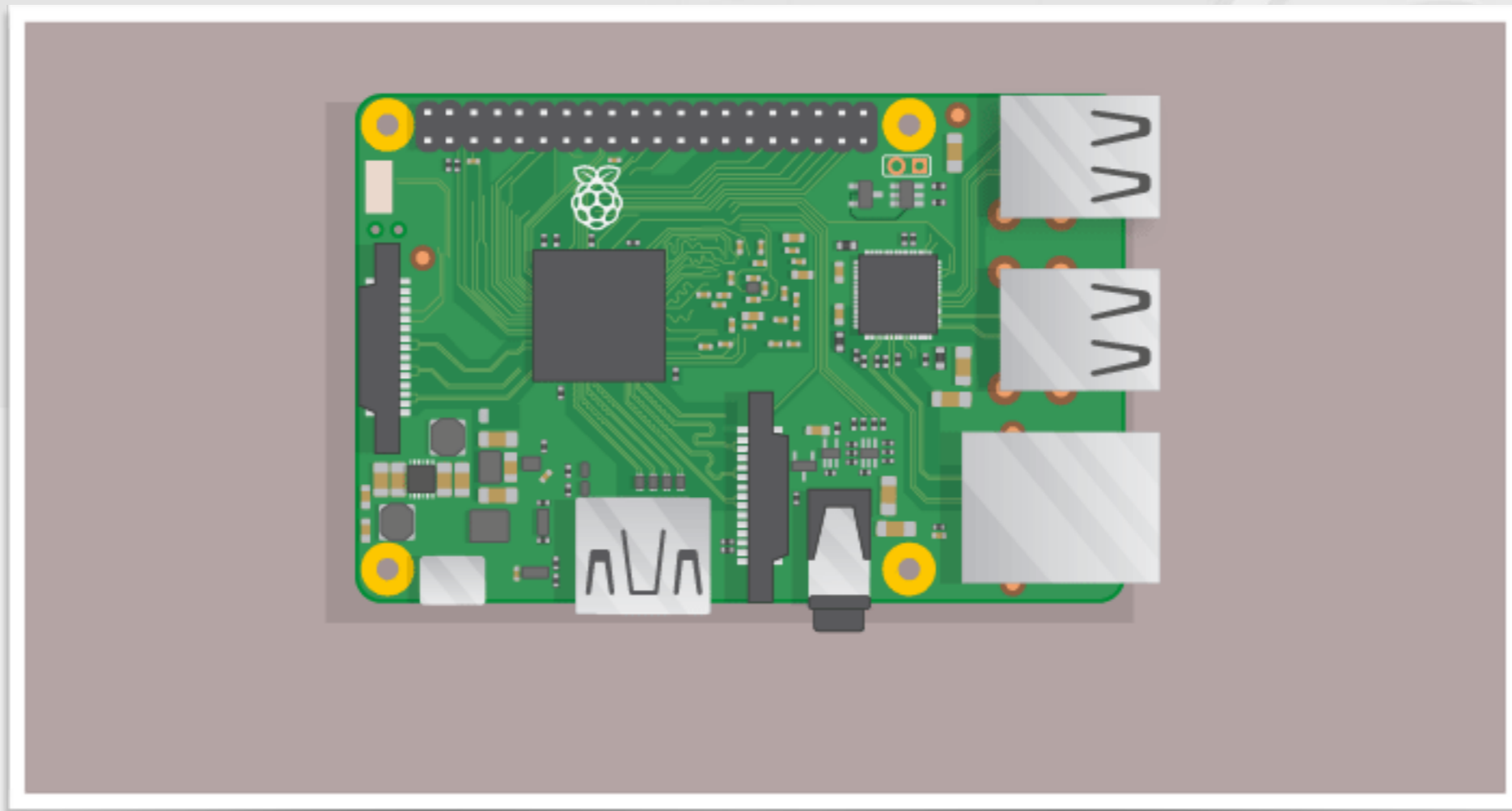

Outline

- Image format and coding methods
- Audio format and coding methods
- Video format and coding methods
- Introduction to HTML and XML
- Graphics format and coding methods





2.1 Image format and coding methods



Common image formats

- General types:

- GIF
- JPEG
- PNG
- TIFF
- TGA

- Raw data:

- RAW
- DNG

- Platform spec.:

- ➔BMP (Win)
- ➔PAINT&PICT (Mac)
- ➔PPM (X-Win)

- Vector data:

- ➔WMF (Win)
- ➔PS and PDF



Common image formats

- Key points of storage
 - Color space
 - Coding (compression) methods
 - Byte order: hardware dependent
 - MSB/LSB (most/least significant byte)



LZW and lossless compression

- Universal lossless data compression algorithm
 - by Abraham Lempel, Jacob Ziv, and Terry Welsh
- The compressor algorithm builds a string translation table from the text being compressed



Lossless image compression methods

- Other lossless image compression methods
 - Image different encoding (差分)
 - Lossless JPEG (JPEG 2000)
 - discrete wavelet transform



Lossy image compression methods

- Quantization
- Transform coding
 - Discrete Cosine Transform => JPEG
 - Discrete Wavelet Transform => JPEG 2000
 - ...

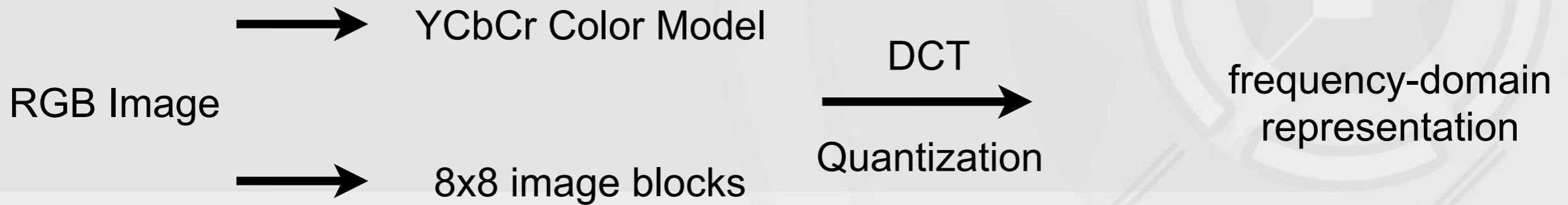

Image compression standards

- JPEG
 - Joint picture encoding group
 - Discrete Cosine Transform
- JPEG 2000
 - newer standard
 - Discrete Wavelet Transform



JPEG compression: main idea



52	55	61	66	70	61	64	73
63	59	55	90	109	85	69	72
62	59	68	113	144	104	66	73
63	58	71	122	154	106	70	69
67	61	68	104	126	88	68	70
79	65	60	70	77	68	58	75
85	71	64	59	55	61	65	83
87	79	69	68	65	76	78	94

16	11	10	16	24	40	51	61
12	12	14	19	26	58	60	55
14	13	16	24	40	57	69	56
14	17	22	29	51	87	80	62
18	22	37	56	68	109	103	77
24	35	55	64	81	104	113	92
49	64	78	87	103	121	120	101
72	92	95	98	112	100	103	99

-26	-3	-6	2	2	-1	0	0
0	-2	-4	1	1	0	0	0
-3	1	5	-1	-1	0	0	0
-4	1	2	-1	0	0	0	0
1	0	0	0	0	0	0	0
0	0	0	0	0	0	0	0
0	0	0	0	0	0	0	0
0	0	0	0	0	0	0	0



JPEG compression: implementation

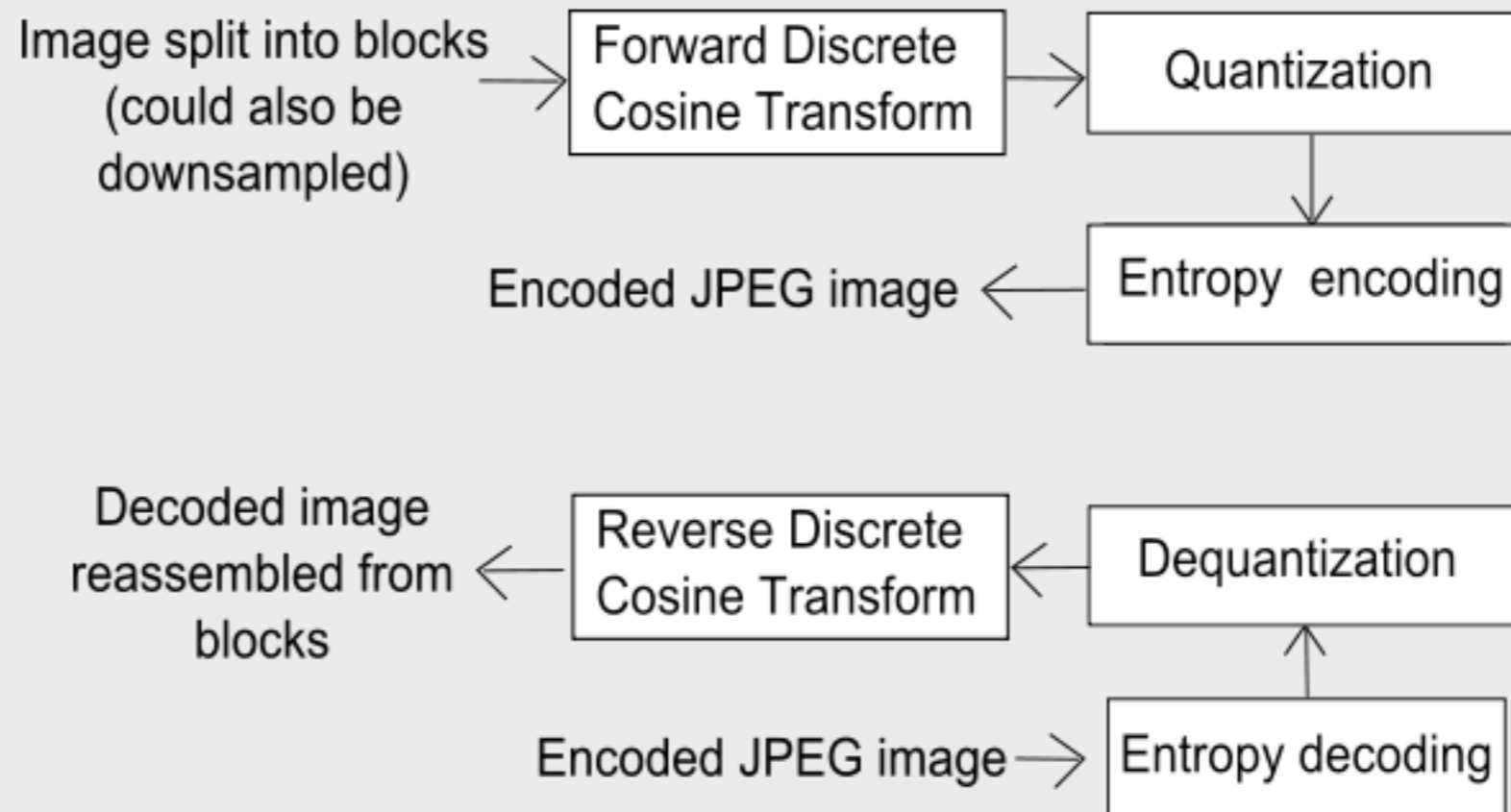

Compression Rate



bpp: bit per pixel

Upper-left: The original image.

Upper-right: Decoded at 0.5 bpp (PSNR: 35.32 dB).

Lower-left: 1.0 bpp (PSNR: 38.73 dB).

Lower-right: 1.5 bpp (PSNR: 41.62 dB).



Common image formats - GIF

- Graphics Interchange Format
 - UNISYS Corporation and Comuserve
 - Lempel-Ziv-Welch compression method
 - GIF87 / GIF89a
 - Features
 - Only support 8-bit (256) color image
 - Support several animation effects
 - Support interlaced image coding



Common image formats - PNG

- Portable Network Graphics
 - motivation: CompuServ owns the LZW coding patent for GIF images
 - open source
 - Transparent
 - PNG64



Common image formats - JPEG

- Lossy to lossless editing



Common image formats - TIFF (6.0)

- Tagged Image File Format
 - flexible and adaptable
 - handling images and data within a single file
 - header tags: size, definition, image-data arrangement, applied image compression
 - defining the image's geometry.



Common image formats - TIFF (6.0)

- a TIFF can be a container file
 - compressed JPEG and RLE
 - lossless compression
- include a vector-based Clipping path (outlines, cropping, image frames)



DNG: Digital Negative



- a royalty free RAW image format
- design by Adobe
- based on TIFF/EP
- mandates use of metadata



Summary – Essential factors of image storage

- Resolution
- Compression rate
 - 1bpp, 2bpp, etc.
- Compression methods
- Color representation
 - RGB, YUV, Lab ...



Image converting tools

- ACDSEE
- XnView
 - <http://perso.orange.fr/pierre.g/>





2.2. Audio formats and compression methods



Digitalized audio / sound



- What is sound?
 - Knowing from ear?!?
 - Sound wave ?!?
- Digitalization
 - Analog signal \rightarrow digital signal
 - Quantization

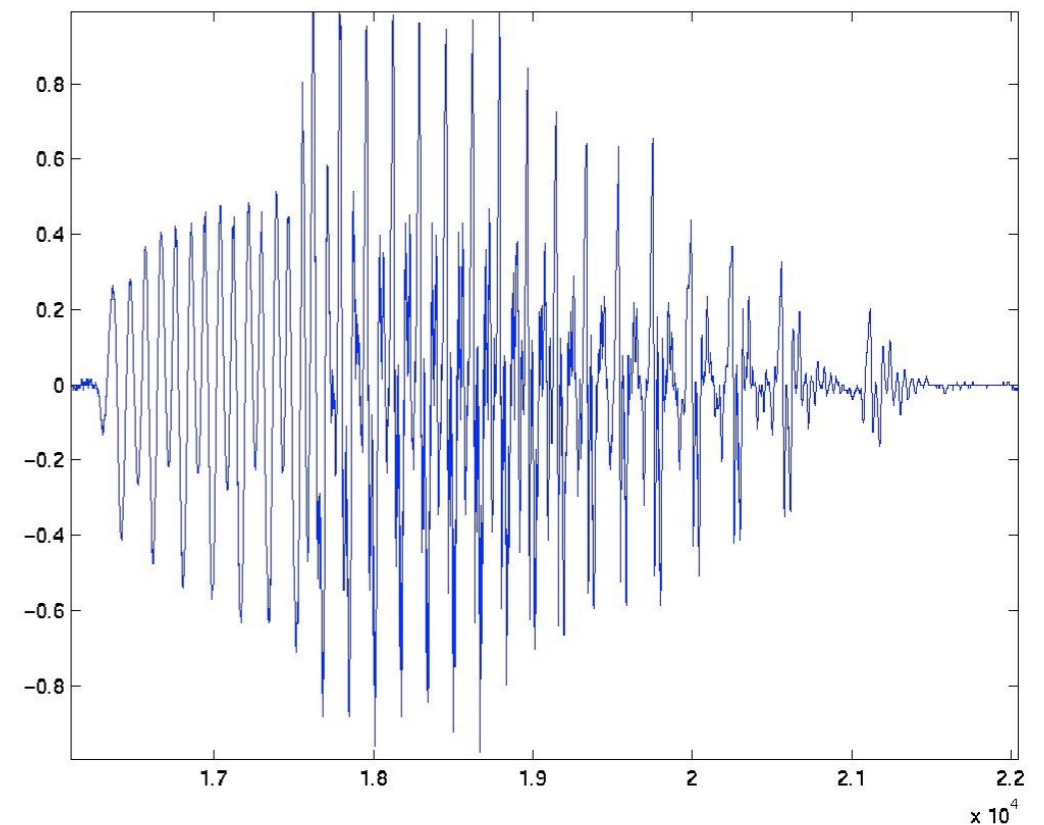

Bit rate and bit

- a kind of energy wave.
- a continuous function of wave amplitude
 - Sequence is related to the X axis (the time line).
 - Amplitude is related to the Y axis. **Higher coding rate and quantization rate, better sampling quality**
- discretely sampled during the digital coding period
 - **Bit rate**: number of samples obtained in one second
 - The highest frequency ~ 20kHz.
 - 40k samples per second (**Nyquist theorem**)
 - The bit rate of CD is 44.1kHz
 - **Quantization rate**: must be the power of 2.
 - The quantization rate of audio CD is normally 16bit.



Audio compression: lossless vs. lossy

- There is no absolute lossless coding schemes!
 - According to the definitions of bit rate and quantization rate, audio coding can only approximate to the natural sound signal as much as possible.
 - Comparing with natural signal, all coding schemes are lossy.
- Related lossless scheme: PCM
 - PCM can reach the highest preserving level.
 - Widely applied in raw data saving and music data, e.g. CD, DVD and WAV files.
 - PCM is viewed as a lossless coding scheme. However, PCM only approximate to the raw data.
 - Comparing with the PCM coding method, we usually put MP3 coding methods into the lossy audio encoding methods.



PCM coding

- PCM - **P**ulse **C**ode **M**odulation
- PCM coding
 - Advantage: good play back quality.
 - Shortage: large storage space.
- Audio CD mainly leverage the PCM coding scheme.
 - One CD can store 72 minutes music.

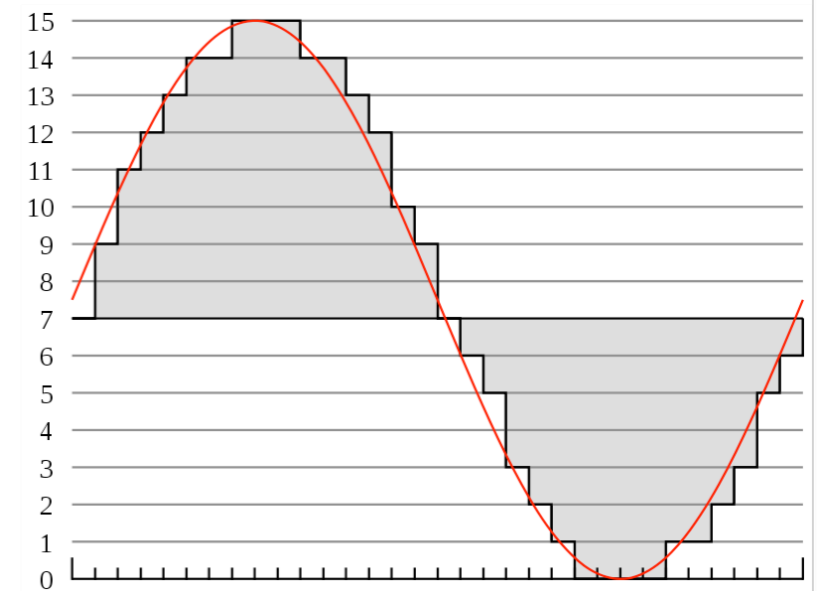

Sampling and quantization of a signal (red) for 4-bit PCM



PCM audio stream bit-rate

- Formula

- Bit rate \times Quantization rate \times number of sound channels (bps)。

- EXAMPLE:

- WAV file: bit rate 44.1KHz, quantization rate 16bit, stereo sound.

- Coding rate: $44.1\text{K} \times 16 \times 2 = 1411.2$ Kbps.

- 128K MP3 ~ 1411.2 K bits per second

- also called data width, similar to the concept of band width used in network transfer.

- Data speed: transferred bytes per second, = Bit rate / 8. In this example, the speed is 176.4KB/s.

- It takes space of 176.4KB per second. Recording 1 minute music requires 10.34M.



The streaming feature of audio

- The blooming of network => play on-line music.
 - play the music meanwhile downloading.
 - Recent techniques are easy to archive this goal.
- Based on this feature, it is easy to implement:
 - on-line direct-show
 - DIY digital broad casting.



Common audio formats

- WAV
- MP3
- WMA
- RA
- OGG
- APE

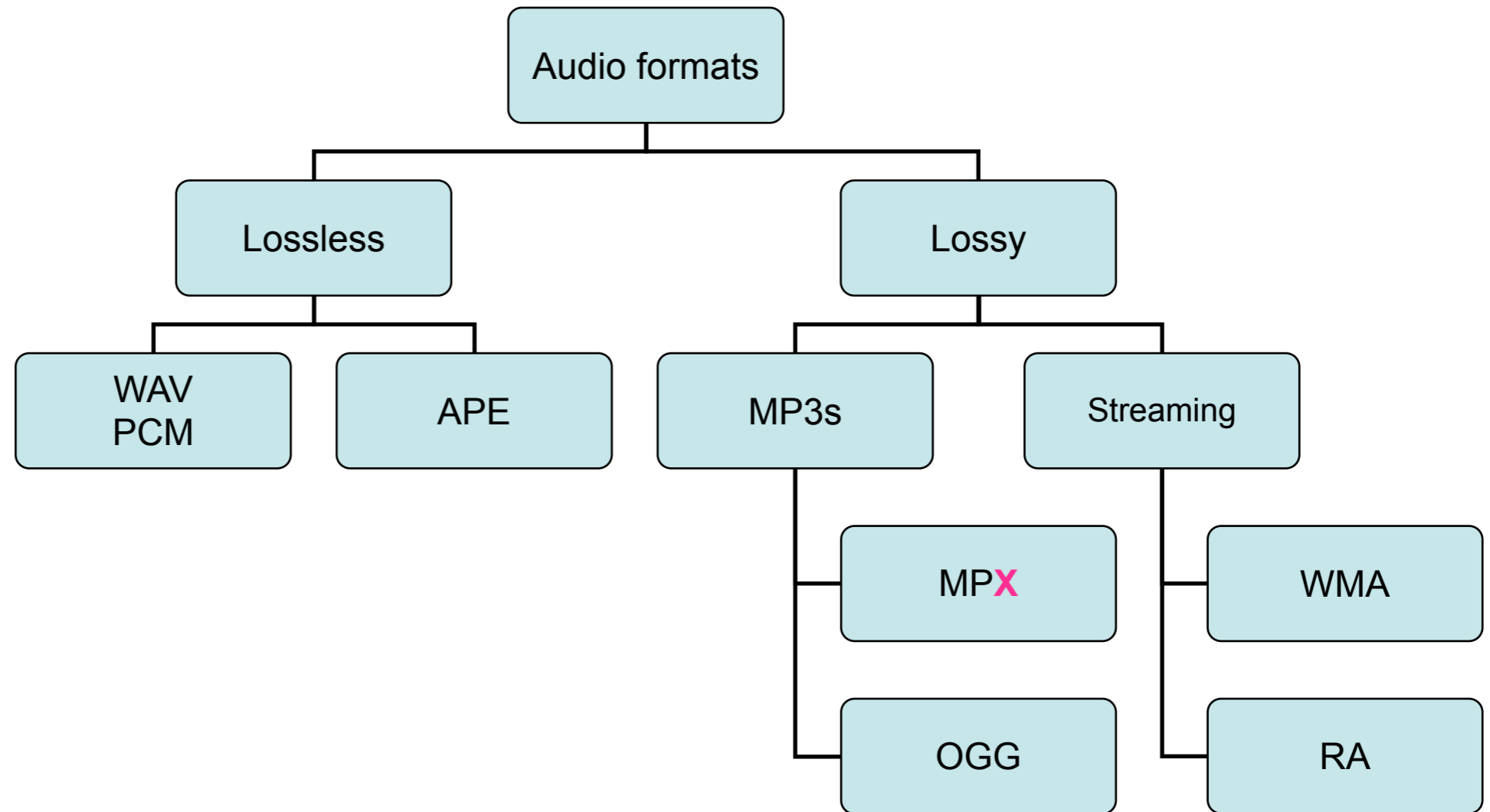

WAV

- Developed by Microsoft
- WAV format is based on RIFF (Resource Interchange File Format) standard.
 - All WAV files have a file head which is used to record coding parameters of audio stream.
 - WAV file have no specific constraints on coding audio stream. Besides PCM, WAV can use any types of coding schemes defined by ACM.
- In Windows, PCM based WAV format is recognized as a most useful audio format.
 - WAV is good for music creating and editing, and for saving raw music data.
 - PCM based WAV file is now employed as an intermediate format for convert over different type of audio data, e.g., MP3 to WMA.



WMA

- WMA is created the Windows Media Audio coding framework, developed by Microsoft.
- WMA is designed to used for network transfer. Its main competitors are products from Real Networks.
 - Microsoft claimed that WMA can reach the sound quality of CD in 64kbps bit rate.
 - Provides Windows Media Rights Manager to prevent illegal copies and to count play times.
 - Supports stream techniques and online broadcasting.



RA

- RA (RealAudio) is proposed by RealNetworks Inc.
- In network application, many music site use RealAudio for online playing.
- RA mainly focus on network media market
 - Highlight: RA can alter its own coding bit rate due to the network width but keep the sound quality as much as possible.
 - RA can support many types of audio coding schemes, e.g., ATRAC3.
 - Beside the function of download-while-play, RA can also hide true internet address of sound file. It is quite useful for Music company



APE

- APE is a lossless compression format proposed by Monkey's Audio.
- They mainly used **LZW** as the compression kernel.
- High compression ratio but fast compression speed.
 - Used by many music fans to record CD and share music resources.
- Monkey's Audio provides a set plug-ins for different types of media players.



MP3

- From the MPEG-3 standard
- Most popular audio file format
- Special compression method for sound

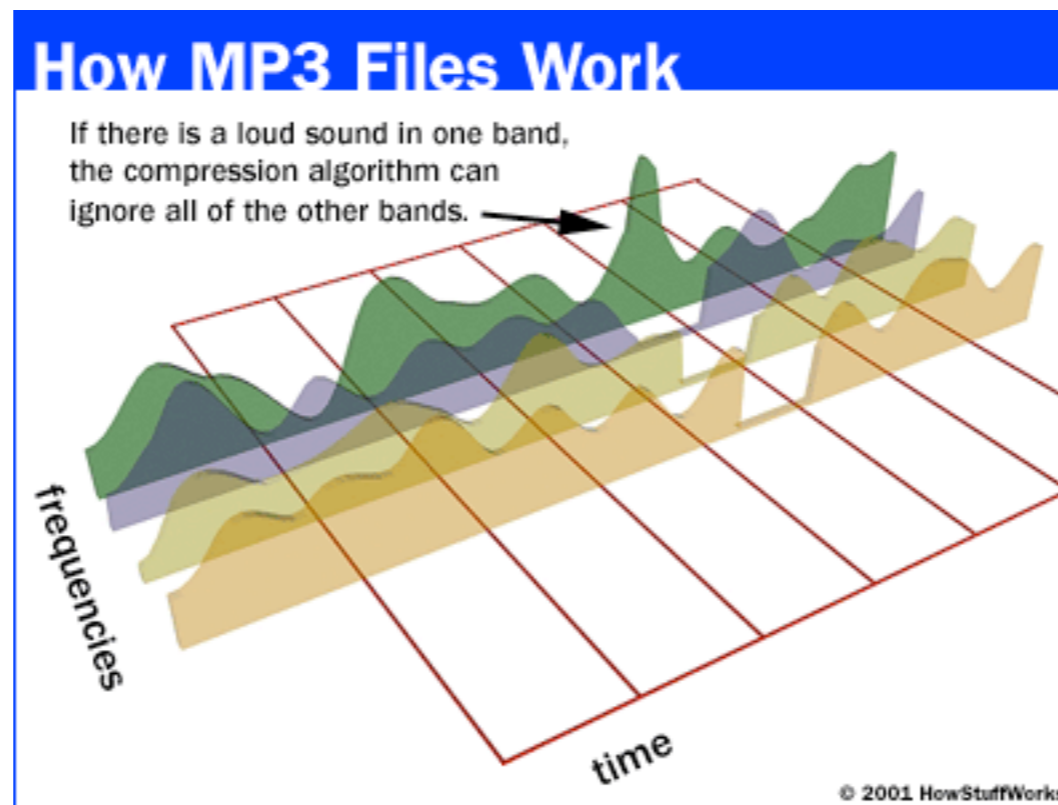

perceptual noise shaping

OGG

- OGG is a huge project plan of multimedia R&D and is mainly focus on video/audio coding.
 - The total OGG project is open source and free
- Ogg Vorbis audio coding
 - Comparing with MP3, it provides lower bit rate but better play back quality.
 - Support more channels than MP3. It is suitable for recoding classical music.
 - Flexible audio coding framework



微软和MIT的脑洞：通过纹身演奏音乐

- <http://www.midifan.com/moduleneews-detailview-27730.htm>

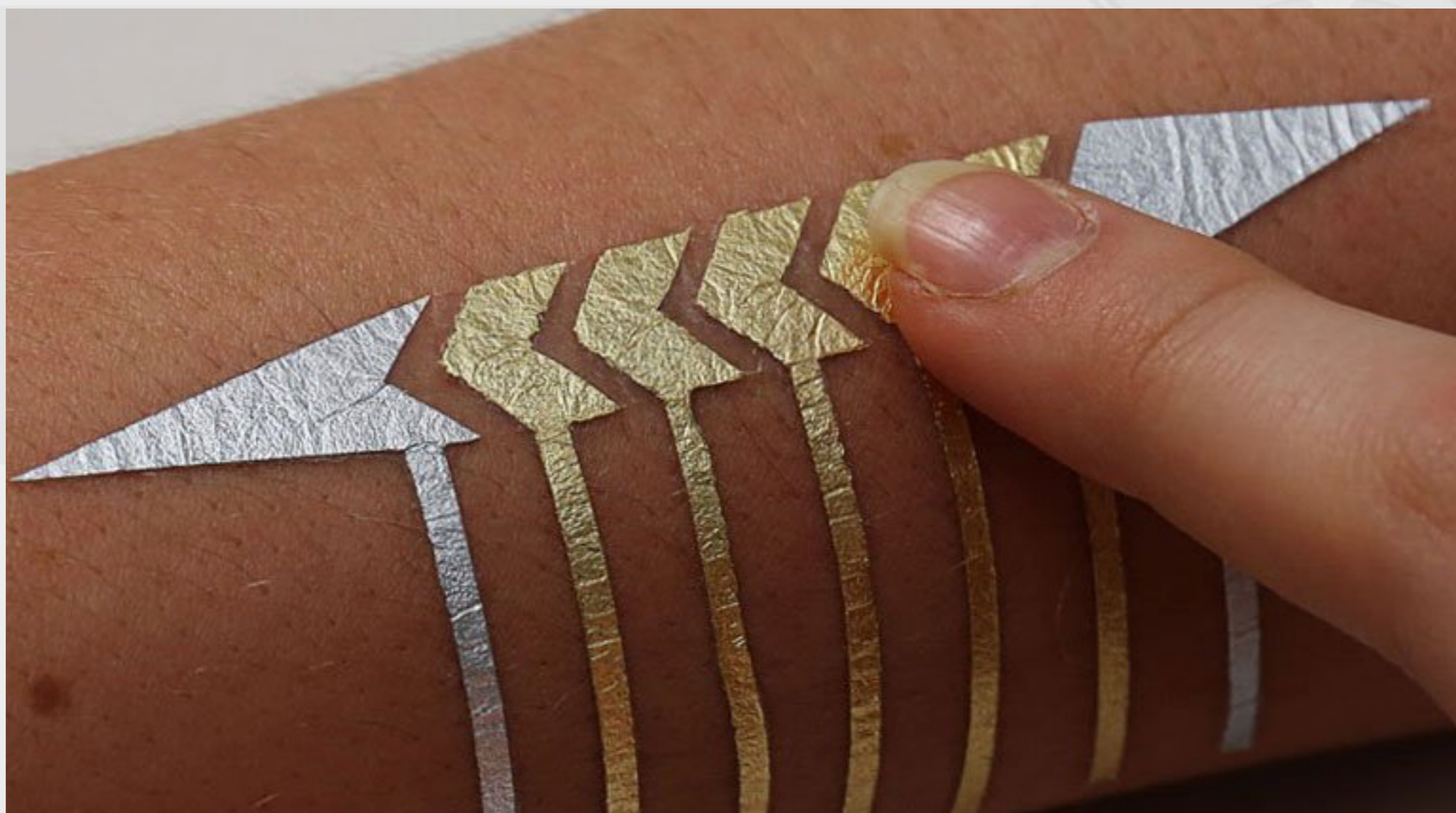

什么是MIDI

- MIDI (**M**usical **I**nstrument **D**igital **I**nterface 即 乐器数字化接口) is an international standard for general interface.
 - It provides a set of standard interface for transferring data among different types of devices. MIDI devices shall precisely send MIDI messages.
- Wildly use in music creation, game background music and ring tone of mobile phones.



MIDI概况

- MIDI is type of description language.
 - Different directly record digitalized sound signal
 - Only record ‘events’ that how instruments make sound.
 - Small storage size.
- Three elements of MIDI
 - Synthesizer
 - Generate sound and can control the length, height, strength and other features of sound.
 - Sequencer
 - Devices or software that store and modify MIDI information.
 - MIDI device
 - Do not generate any sound but a sequence of MIDI commands.
 - E.g. MIDI keyboard, MIDI harp, MIDI guitar, and MIDI violin, etc.



Basic concepts of MIDI

- [Track]
 - Music is composed with several music channels.
- [Channel]
 - Each MIDI device corresponds to a channels. Each channel owns its own message sequence. Up to 16 channels
- [Voice]
 - Each channel allows multiple voice, e.g., chords when playing piano. (*Timbre* means the sum of sound in one channels)
- [Polyphony]
 - The sum of sound can be generated by Synthesizer in one moment.
- [Patch]
 - Sound feature setting up to simulate specific instrument.



Message structure of MIDI

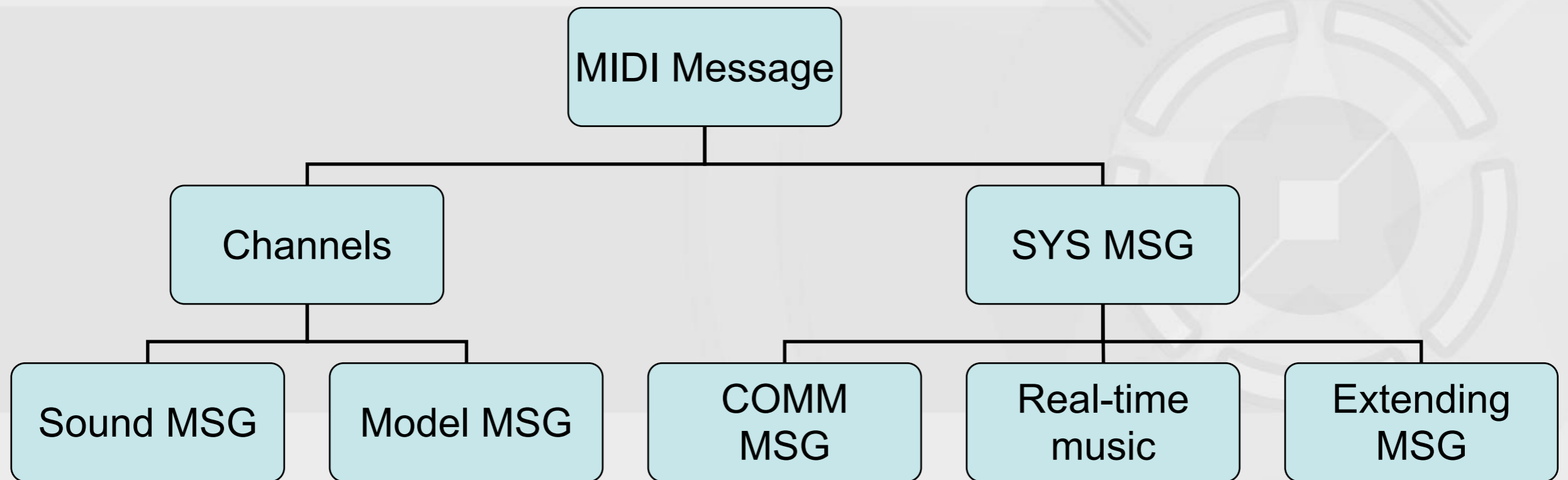

Common MIDI file format

- MID
 - General MIDI
- SMF
 - Standard MIDI File





2.3. Video formats and coding methods



Representations of video

- Sequence of images ?!?
 - Can be viewed as a 3-dimensional matrix
 - But it is only 50% correct

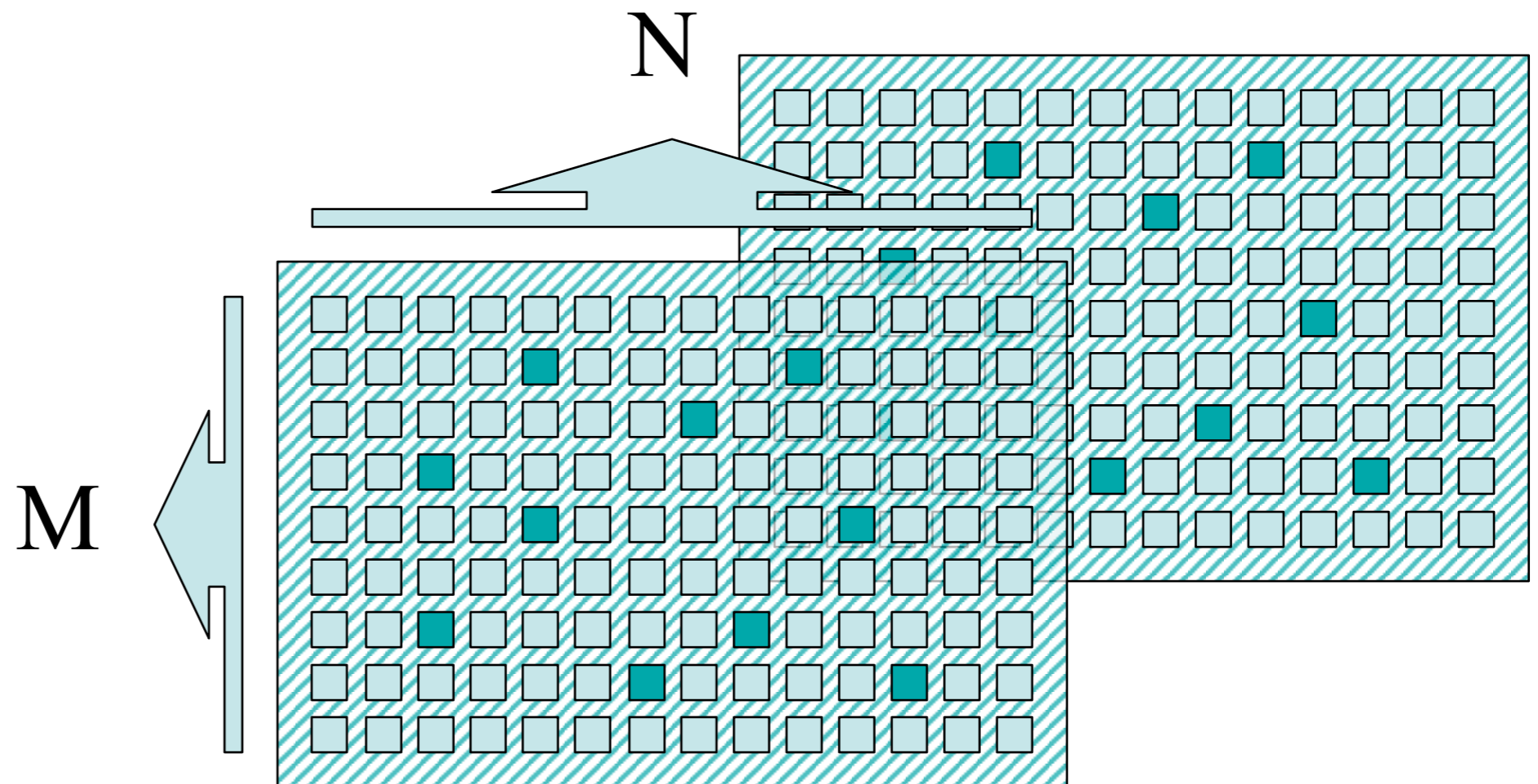

Common video formats

- AVI (Microsoft, Divx, ...)
 - avi, wmv, asf
- RM (Realplayer)
 - rm, rmvb
- MOV (Quicktime)
 - mov
- MPEG
 - MPEG-1, MPEG-2, MPEG-4 ...



<http://www.bigbuckbunny.org/index.php/download/>



Common video formats - AVI

- AVI = Audio Video Interleaved (By Microsoft)
 - A digital audio/video format according to the [RIFF file format standard](#).
 - multimedia CDROM, store video information, movie and TV program,
 - Internet applications, download and online viewing
- Allows storing audio and video information [interlaced](#)
- But play back [simultaneously](#)



Common video formats - AVI

- AVI only defines the standard on control interface.
 - **No limitation of compression** approach in AVI file format
 - Supports 256 colors and RLE compression
 - AVI with specific **encoding methods** must be played back by matched **decoding methods**.
 - Many companies provide their own codecs
 - e.g., SONY



Common video formats - RM



- RM (RealVideo file): a new file format for **streaming video** by RealNetworks Inc.
- RealVideo techniques is used to broadcast important events over Internet.
- RealMedia: A audio/video compression standard of RealNetworks
 - Mainly used in wide range network to transform real-time video sequence in low bit rate.
 - It can alter different bit rate depends on network data transformation rate
- RealVideo can be used with RealServer. Different from most other video formats, RM can be played back while the data is downloading.



Common video formats - MOV

- A video/audio format developed by Apple Inc.
- QuickTime™ player
 - Apple Mac OS、 Microsoft Windows System
- The original format supports
 - 256 color, RLE, and JPEG compression techniques.



Common video formats - MOV

- Advanced function features
 - > 150 kinds of Video effects
 - > 200 kinds of MIDI devices sounds.
- Internet-oriented features
 - digitalized information stream,
 - workflow, and
 - play-back functions through internet.



Common video formats - MOV

- QuickTime VR (QTVR):
 - a set of **Virtual Reality** (虚拟现实) techniques used in QuickTime.
 - use mouse or keyboard
 - investigate 360 degree of scene
 - browse an object from a specific spatial angle interactively.



Video compression standards

- **MPEG standards**
 - Audio/Video compression, storage and play back standards
 - MPEG-1: VCD
 - MPEG-2: broadcast TV, e.g., DVD、HDTV etc.
 - MPEG-3: replaced by MPEG-2
 - MPEG-4: network video transfer, stream media
 - MPEG-7:
 - MPEG-21:
- **ITU-T H.26x series**



Video compression standards

- ITU-T H.26x series
 - Mainly used in [video communication applications](#)
 - Now it has H.261, H.262, H.263, H.264
 - ISDN network based H.320 standards
 - the video compression part: H.261, H.262 and H.263
 - LAN network based H.323
 - PSTN network based H.324
 - the video compression part: H.261 and H.263



MPEG概况

- MPEG = **M**otion **P**icture **E**xpert **G**roup
- **ISO/IEC JTC1/SC29**
 - WG11: Motion Picture Experts Group (MPEG)
 - WG10: Joint Photographic Experts Group (JPEG)
 - WG7: Computer Graphics Experts Group (CGEG)
 - WG9: Joint Bi-level Image coding experts Group (JBIG)
 - WG12: Multimedia and Hypermedia information coding Experts Group (MHEG)



MPEG概况

- **MPEG-1,2** standards were started at 1988
 - 需求 [Requirement]
 - 系统 [System]
 - 视频 [Video]
 - 音频 [Audio]
 - 实现 [Implementation]
 - 测试 [Testing]
- Newest MPEG standards: **MPEG-4, MPEG-7, MPEG-21**



MPEG-1 Standard ISO/IEC 11172-2 (1991)

"Coding of moving pictures and associated audio for digital storage media"

• Video

- optimized for bit rates around 1.5 Mbit/s
- originally optimized for SIF picture format,
- but not limited to it:
 - [**NTSC based**] : 352x240 pixels at 30 frames/sec
 - [**PAL based**] : 352x288 pixels at 25 frames/sec
- progressive frames only
 - no direct provision for interlaced video applications, such as broadcast television



MPEG-1 Standard ISO/IEC 11172-2 (1991)

- **Audio**

- joint stereo audio coding at 192 kbit/s (layer 2)

- **System**

- mainly designed for error-free digital storage media
 - multiplexing of audio, video and data

- **Applications**

- CD-I, digital multimedia, and
 - video database (e.g. video-on-demand)



MPEG-2 Standard ISO/IEC 13818-2 (1994)

- Video

- 2-15 or 16-80 Mbit/s bit rate (target bit rate: 4...9 Mbit/sec)
- TV and HDTV picture formats
- Supports interlaced material

- MPEG-2 consists of *profiles* (类) and *levels* (级)
 - Main Profile, Main Level (MP@ML)
 - 720x480 resolution video at 30 frames/sec
 - < 15 Mbit/sec (typical ~4 Mbit/sec)
 - for NTSC video

 - Main Profile, High Level (MP@HL)
 - 1920x1152 resolution video at 30 frames/sec
 - < 80 Mbit/sec (typical ~15 Mbit/sec)
 - HDTV



MPEG-2 Standard ISO/IEC 13818-2 (1994)

- Audio
 - compatible multichannel extension of MPEG-1 audio
- System
 - video, audio and data multiplexing defines two presentations:
 - **Program Stream** for applications using near error free media
 - **Transport Stream** for more error prone channels
- Applications
 - satellite, cable, and terrestrial broadcasting,
 - digital networks, and
 - digital VCR



MPEG compression is based on 8 x 8 pixel **block processing**

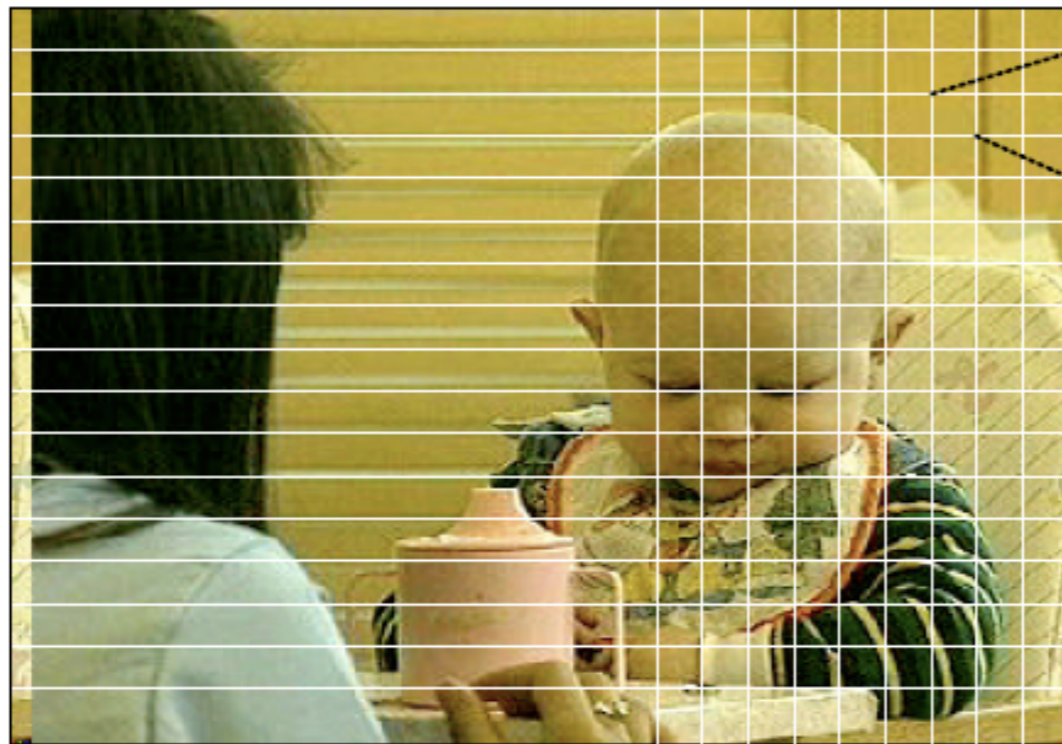

8 pixels

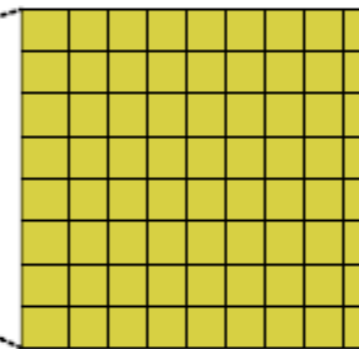

8 pixels

- 8 x 8 pixel block can be numerically manipulated by fast signal processor in real time
- Motion estimation is based on comparing the blocks between series of pictures



MPEG: only compress moving parts

new picture



previous picture



difference



Encoder

Decoder

difference



previous picture



new picture



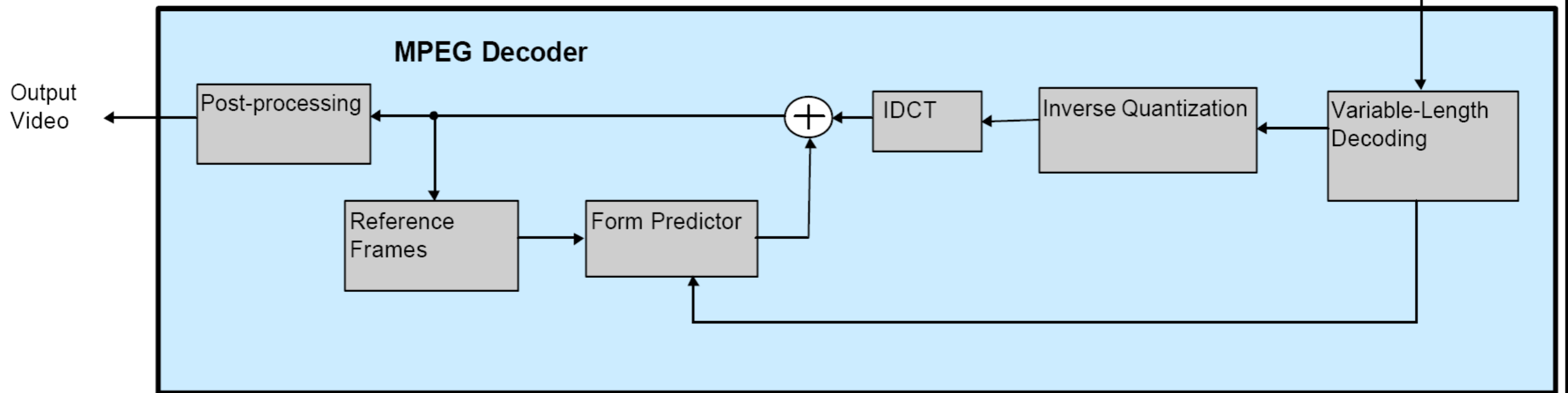
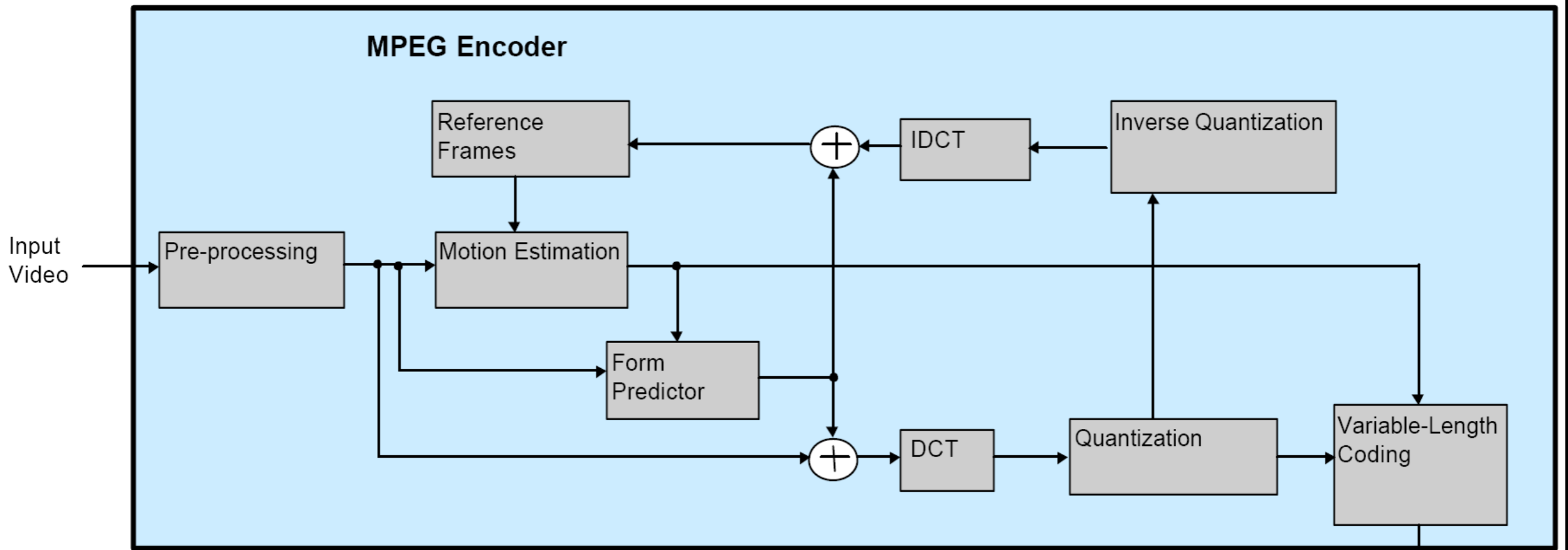

MPEG: motion compression

I = Intra-Frame
P = Predicted frame
B = Bi-directionally
interpolated frame

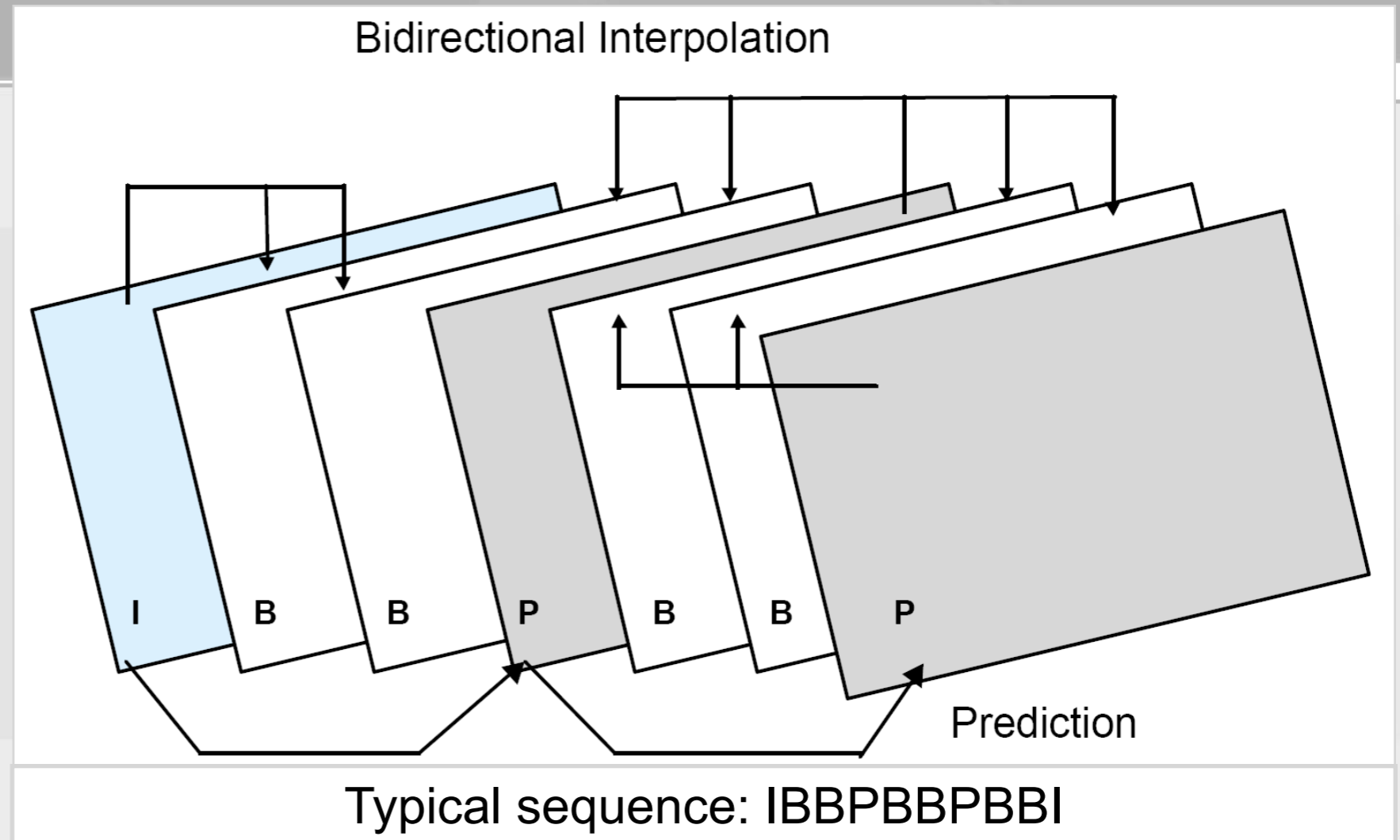

Video signal: stream of picture, it is not necessary to send every picture

- Whole picture is needed only when all the content is changed!
- Several pictures has to be buffered to memory to make prediction forward and backward



MPEG: other issues

- Motion compensating
- Intra-frame transfer order

